



# **GPS GMOUSE G11**

## **Specification**

Ver.1.0

# Update

---

No.	Verison	Update	Revise
1	Ver.1.0	Initial	March, 3 <sup>th</sup> , 2020

# General Description

The AGM-41R-20W004 module series is a family of stand alone GPS receivers featuring the high performance u-blox 7 positioning engine. These flexible and cost effective receivers offer numerous connectivity options in a miniature 45x38x13mm package. Their compact architecture and power and memory options make AGM-41R-20W004 modules ideal for battery operated mobile devices with very strict cost and space constraints.

The 56-channel u-blox M8 positioning engine boasts a Time-To-First-Fix (TTFF) of under 1 second. The dedicated acquisition engine, with over 1 million correlators is capable of massive parallel time/frequency space searches, enabling it to find satellites instantly. Innovative design and technology suppresses jamming sources and mitigates multipath effects, giving AGM-41R-20W004 GPS receivers excellent navigation performance even in the most challenging environments.

## Applications

- UVA (unmanned aerial vehicle)
- DVR (Digital Video Recording)
- Rearview mirror DVR
- Car Tracker



Figure: AGM-41R-20W004 Top View

Main chip	UBX-G7020-KT
Track sensitivity	-165dBm
Time to First Fix	Extremely fast at low signal level
Built in high LNA	YES
Power consumption	Max 25mA@3.3V
Protocol	NMEA-0183 compliant protocol or custom protocol
Operating temperature	-40 to 85°C
Operating voltage	3.0V to 5.0V
Module type	UART/TTL
Size	40.5*37*13mm
Certification	RoHS compliant(Lead-free)

# 1 Description

## 1.1. Key Features

Parameter	Specification
Power Supply	<ul style="list-style-type: none"> <li>Supply voltage: 3.0V~5.0V Typical: 3.3V</li> </ul>
Power Consumption	<ul style="list-style-type: none"> <li>Acquisition: 25mA @VCC=VBAT=3.3V</li> <li>Tracking: 20mA @VCC=VBAT=3.3V</li> <li>Backup: 15uA @VBAT=3.3V</li> </ul>
Receiver Type	<ul style="list-style-type: none"> <li>Code 56 search channels ,22 synchronous tracking channels</li> <li>GPS&amp;QZSS L1 1575.42MHz C/A ,GLONASS L1OF1602MHz, SBAS: WAAS, EGNOS, MSAS, GAGAN</li> </ul>
Sensitivity	<ul style="list-style-type: none"> <li>Tracking: -165dBm</li> <li>Re-acquisition: -156dBm</li> <li>Acquisition: -146dBm</li> </ul>
TTF (Autonomous)	<ul style="list-style-type: none"> <li>Cold start: 35s typ @-130dBm</li> <li>Warm start: 30s typ @-130dBm</li> <li>Hot start: 1s typ @-130dBm</li> </ul>
Horizontal Position Accuracy (Autonomous)	<ul style="list-style-type: none"> <li>&lt;2.5m CEP @-130 dBm</li> </ul>
Max Update Rate	<ul style="list-style-type: none"> <li>Up to 10Hz, 1Hz by fault</li> </ul>
Accuracy of 1PPS Signal	<ul style="list-style-type: none"> <li>not enabled</li> </ul>
Acceleration Accuracy	<ul style="list-style-type: none"> <li>Without aid: 0.1m/s<sup>2</sup></li> </ul>
Dynamic Performance	<ul style="list-style-type: none"> <li>Maximum altitude: 18,000m</li> <li>Maximum velocity: 515m/s</li> <li>Acceleration: 4G</li> </ul>
UART Port	<ul style="list-style-type: none"> <li>UART Port: TXD and RXD</li> <li>Supports baud rate from 4800bps to 115200bps, 9600bps by default</li> <li>UART port for NMEA and UBX output, binary or ublox proper Agreement input</li> </ul>
Temperature Range	<ul style="list-style-type: none"> <li>Normal operation: -40°C ~ +85°C</li> <li>Storage temperature: -45°C ~ +125°C</li> </ul>
Physical Characteristics	<ul style="list-style-type: none"> <li>Size: 40.5±0.20 × 37±0.20 × 13±0.50mm</li> <li>Connecting line specifications: Molex 2*2Pin , L=2M</li> <li>Weight: Approx.86g</li> </ul>

## 1.2 Power Supply

Regulated power for the AGM-41R-20W004 is required. The VCC Pin Need a stable DC voltage supply. Power supply ripple must be less than 30mV. The input voltage Vcc should be 3.0V~5.0V, Recommended power supply voltage is 3.3V . maximum current is 25mA. Suitable decoupling must be provided by external decoupling circuitry.

## 1.3 UART Ports

The module supports two full duplex serial channels UART. All serial connections are at 3V CMOS logic levels, if need different voltage levels, use appropriate level shifters. The baud rate of both serial ports are fully programmable, the data format is however fixed: X, N, 8, 1, i.e. X baud rate, no parity, eight data bits and one stop bit, no other data formats are supported, LSB is sent first. The modules default baud rate is set up 9600bps, however, the user can change the default baud rate to any value from 4800 bps to 115kbps. UART port can be used for firmware upgrade, NMEA output and ublox proprietary commands input.

# 2 Application

---

The Gmouse is equipped with a Molex 2\*2Pin connects to your application platform.

The AGM-41R-20W004 Gmouse It consists of a ublox UBX-G7020-KT single chip GPS IC which includes the RF part and Baseband part, a patch antenna, a LNA, a SAW filter, a TCXO, a crystal oscillator, Also comes with a 0.22F crystal capacitor ,can backup satellite ephemeris about 2 hour.

## 2.1. Pin Assignment

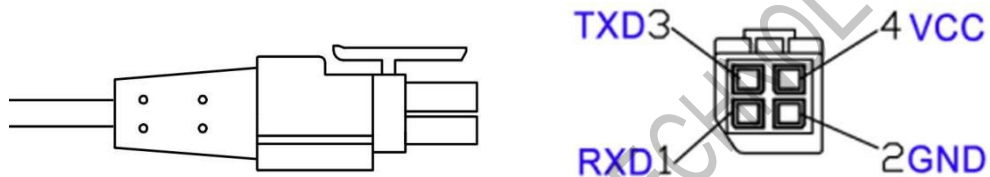

Figure 2: Pin Assignment

## CON Pin Description

Pin No.	Pin name	I/O	Description	Remark
1	RXD	I	UART Serial Data Input	
2	GND	G	Ground	
3	TXD	O	UART Serial Data output	
4	VCC	I	Module Power Supply	Voltage range: 3.0V~5.0V

## 2.2 Mechanical Dimensions

This chapter describes the mechanical dimensions of the AGM-41R-20W004 module. Size unit (mm)

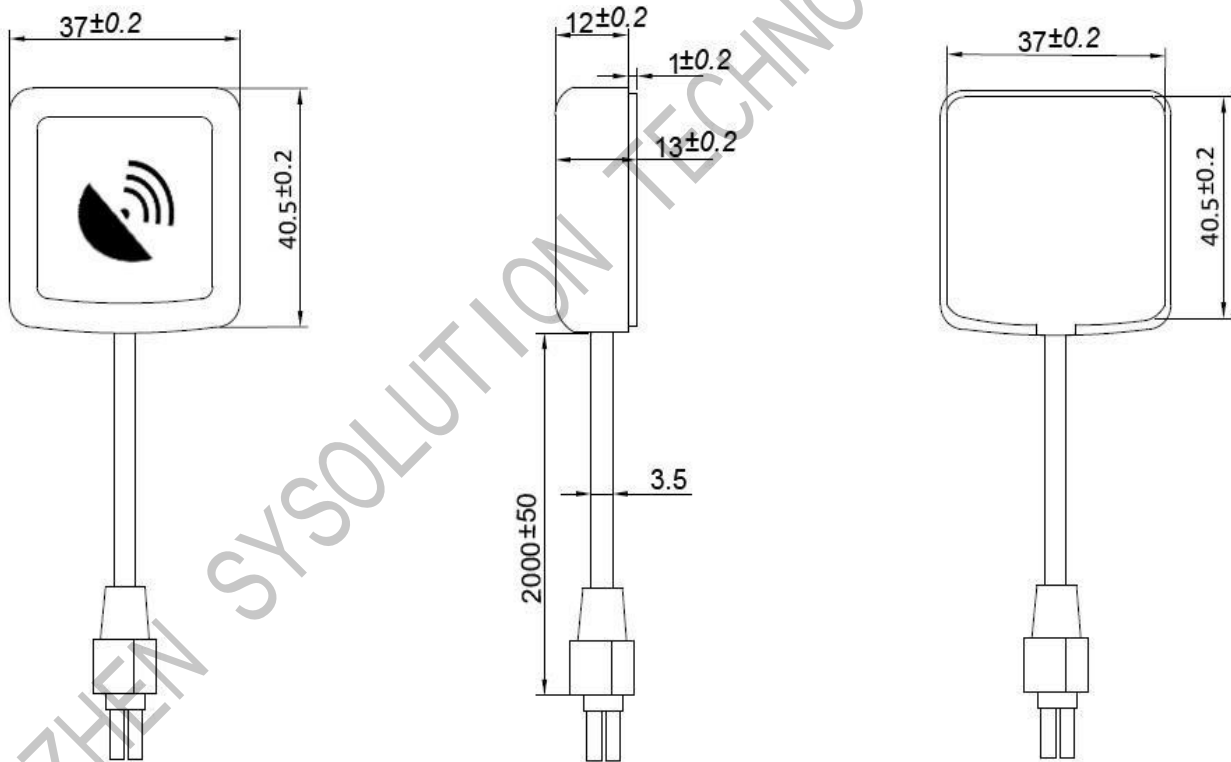

**Figure 3:** Specification size chart

## 3 Configuration instruction Explain

The module supports the commonly used commands in configuration, The following table describes some of the parameters of the UART port configuration command, baud rate setting: NMEA data refresh rate is set, the NMEA statement output set, positioning mode setting etc.

The Module power up initialization requires 300ms, Please send the sixteen system from CPU via serial port.

### 3.1 Baud rate configuration command

Common commands	Instructions
<b>Cold star</b>	B5 62 06 04 04 00 FF FF 02 00 0E 61
<b>Hot start</b>	B5 62 06 04 04 00 00 00 02 00 10 68
<b>Reset</b>	B5 62 06 04 04 00 FF 87 01 00 95 F7
<b>Restore factory settings</b>	B5 62 06 09 0D 00 FF FF 00 00 00 00 00 FF FF 00 00 07 1F 9E
<b>Save configuration</b>	B5 62 06 09 0D 00 00 00 00 00 FF FF 00 00 00 00 00 00 17 31 BF
<b>Baud rate is 4800bps</b>	b5 62 06 00 14 00 01 00 00 00 d0 08 00 00 c0 12 00 00 07 00 07 00 00 00 00 00 d3 fc b5 62 06 00 01 00 01 08 22
<b>Baud rate is 9600bps</b>	b5 62 06 00 14 00 01 00 00 00 d0 08 00 00 80 25 00 00 07 00 07 00 00 00 00 00 a6 cd b5 62 06 00 01 00 01 08 22
<b>Baud rate is 38400bps</b>	b5 62 06 00 14 00 01 00 00 00 d0 08 00 00 00 96 00 00 07 00 07 00 00 00 00 00 97 a8 b5 62 06 00 01 00 01 08 22
<b>Baud rate is 115200bps</b>	b5 62 06 00 14 00 01 00 00 00 d0 08 00 00 00 c2 01 00 07 00 07 00 00 00 00 00 c4 96 b5 62 06 00 01 00 01 08 22
<b>NMEA data refresh rate is 1Hz</b>	B5 62 06 08 06 00 E8 03 01 00 01 00 01 39
<b>NMEA data refresh rate is 2Hz</b>	B5 62 06 08 06 00 F4 01 01 00 01 00 0B 77
<b>NMEA data refresh rate is 4Hz</b>	B5 62 06 08 06 00 FA 00 01 00 01 00 10 96
<b>NMEA data refresh rate is 5Hz</b>	B5 62 06 08 06 00 C8 00 01 00 01 00 DE 6A B5 62 06 08 00 00 0E 30
<b>NMEA data refresh rate is 10Hz</b>	B5 62 06 08 06 00 64 00 01 00 01 00 7A 12 B5 62 06 08 00 00 0E 30



### 3.2 NMEA statement content output configuration

Statement conten	Instructions
Close GGA OutPut	24 45 49 47 50 51 2c 47 47 41 2a 32 37 0d 0a b5 62 06 01 03 00 f0 00 00 fa0f
Close GLL OutPut	24 45 49 47 50 51 2c 47 4c 4c 2a 32 31 0d 0a b5 62 06 01 03 00 f0 01 00 fb11
Close GSA OutPut	24 45 49 47 50 51 2c 47 53 41 2a 33 33 0d 0a b5 62 06 01 03 00 f0 02 00 fc13
Close GSV OutPut	24 45 49 47 50 51 2c 47 53 56 2a 32 34 0d 0a b5 62 06 01 03 00 f0 03 00 fd15
Close RMC OutPut	24 45 49 47 50 51 2c 52 4d 43 2a 33 41 0d 0a b5 62 06 01 03 00 f0 04 00 fe17
Close VTG OutPut	24 45 49 47 50 51 2c 56 54 47 2a 32 33 0d 0a b5 62 06 01 03 00 f0 05 00 ff19
Open GGA OutPut	24 45 49 47 50 51 2c 47 47 41 2a 32 37 0d 0a b5 62 06 01 03 00 f0 00 01 fb10
Open GLL OutPut	24 45 49 47 50 51 2c 47 4c 4c 2a 32 31 0d 0a b5 62 06 01 03 00 f0 01 01 fc12
Close GSA OutPut	24 45 49 47 50 51 2c 47 53 41 2a 33 33 0d 0a b5 62 06 01 03 00 f0 02 00 fc13
Close GSV OutPut	24 45 49 47 50 51 2c 47 53 56 2a 32 34 0d 0a b5 62 06 01 03 00 f0 03 00 fd15
Close RMC OutPut	24 45 49 47 50 51 2c 52 4d 43 2a 33 41 0d 0a b5 62 06 01 03 00 f0 04 00 fe17
Close VTG OutPut	24 45 49 47 50 51 2c 56 54 47 2a 32 33 0d 0a b5 62 06 01 03 00 f0 05 00 ff19
GSV 5S Output once	B5 62 06 01 08 00 F0 03 00 05 00 00 00 00 07 51
Output only RMC	B56206010300F00100FB11B56206010300F00200FC13B56206010300F00300FD15B56206010300F00500FF19B56206010300F00000FA0F

# 4 NMEA 0183 Protocol

The NMEA protocol is an ASCII-based protocol, Records start with a \$ and with carriage return/line feed. GPS specific messages all start with \$GPxxx is a three-letter identifier of the message data that follows. NMEA messages have a check sum, which allows detection of corrupted data transfers.

- ✧ The ASIR AGM-41R-20W004 supports the following NMEA-0183 messages: \$GPGGA, \$GPGLL, \$GPGSA, \$GPGSV, \$GPRMC and \$GPVTG.

**Table 1: NMEA-0183 Output Messages**

NMEA Record	DESCRIPTION
GGA	Global positioning system fixed data
GLL	Geographic position—latitude/longitude
GSA	GNSS DOP and active satellites
GSV	GNSS satellites in view
RMC	Recommended minimum specific GNSS data
VTG	Course over ground and ground speed

## 4.1 GGA-Global Positioning System Fixed Data

\$GPGGA, 161229.487,3723.24751,N, 12158.34160,W, 1,07,1.0,9.0,M.0000\*18

**Table 2: GGA Data Format**

Name	Example	Units	Description
Message ID	\$GPGGA		GGA protocol header
UTC Position	161229.487		hhmmss.sss
Latitude	3723.24571		ddmm.mmmmm
N/S indicator	N		N=north or S=south
Longitude	12158.34160		dddmm.mmmmm
E/W Indicator	W		E=east or W=west
Position Fix Indicator	1		See Table 2-1
Satellites Used	07		Range 0 to 12
HDOP	1.0		Horizontal Dilution of Precision
MSL Altitude	9.0	meters	
Units	M	meters	
Geoids Separation		meters	

Units	M	meters	
Age of Diff.Corr.		second	Null fields when DGPS is not Used
Diff.Ref.Station ID	0000		
Check sum	*18		
<CR> <LF>			End of message termination

**Table 2-1: Position Fix Indicators**

Value	Description
0	Fix not available or invalid
1	GPS SPS Mode, fix valid
2	Differential GPS, SPS Mode, fix valid
3	GPS PPS Mode, fix valid

#### 4.2 GLL-Geographic Position – Latitude/Longitude

\$GPGLL , 3723.24755, N,12158.34161, W,161229.487, A\*2C.

**Table 3: GLL Data Format**

Name	Example	Units	Description
Message ID	\$GPGLL		GLL protocol header
Latitude	3723.24755		ddmm.mmmmm
N/S Indicator	N		N=north or S=south
Longitude	12158.34161		dddmm.mmmmm
E/W Indicator	W		E=east or W=west
UTC Position	161229.487		hhmmss.sss
Status	A		A=data valid or V=data not valid
Check sum	*2C		
<CR> <LF>			End of message termination

#### 4.3 GSA-GNSS DOP and Active Satellites

\$GPGSA , A, 3, 07, 02, 26,27, 09, 04,15, , , , , 1.8,1.0,1.5\*33.

**Table 4: GSA Data Format**

Name	Example	Units	Description
Message	\$GPGSA		GSA protocol header

Mode 1	A		See Table 4-2
Mode 2	3		See Table 4-1
Satellite Used	07		Sv on Channel 1
Satellite Used	02		Sv on Channel 2
...	...		...
Satellite Used			Sv on Channel 12
PDOP	1.8		Position Dilution of Precision
HDOP	1.0		Horizontal Dilution of Precision
VDOP	1.5		Vertical Dilution of Precision
Check sum	*33		
<CR> <LF>			End of message termination

**Table 4-1: Mode 1**

Value	Description
1	Fix not available
2	2D
3	3D

**Table 4-2: Mode 2**

Value	Description
M	Manual-forced to operate in 2D or 3D mode
A	Automatic-allowed to automatically switch 2D/3D

#### 4.4 GSV-GPS Satellites in View

\$GPGSV , 2, 1, 07, 07, 79,048, 42, 02, 51,062, 43, 26, 36,256, 42, 27, 27, 138,42\*71

\$GPGSV , 2, 2, 07, 09, 23,313, 42, 04, 19, 159, 41, 15,12,041, 42\*41.

**Table 5: GGA Data Format**

Name	Example	Units	Description
Message ID	\$GPGSV		GSV protocol header
Number of Message	2		Range 1 to 3
Message Number	1		Range 1 to 3
Satellites in View	07		
Satellite ID	07		Channel 1(Range 1 to 32)

Elevation	79	degrees	Channel 1(Maximum 90)
Azinmuth	048	degrees	Channel 1(True, Range 0 to 359)
SNR(C/NO)	42	dB/Hz	Range 0 to 99,null when not tracking
...			...
Satellite ID	27		Channel 4(Range 1 to 32)
Elevation	27	degrees	Channel 4(Maximum 90)
Azimuth	138	degrees	Channel 4(True, Range 0 to 359)
SNR(C/NO)	42	dB/Hz	Range 0 to 99, null when not tracking
Check sum	*71		
<CR> <LF>			End of message termination

Depending on the number of satellites tracked multiple messages of GSV data may be required.

#### 4.5 RMC-Recommended Minimum Specific GNSS Data

\$GPRMC, 161229.487, A, 3723.24751, N, 12158.34161, W, 0.13,309.62, 120598,, \*10

**Table 6: RMC Data Format**

Name	Example	Units	Description
Message ID	\$GPRMC		RMC protocol header
UTC Position	161229.487		hhmmss.sss
Status	A		A=data valid or V=data not valid
Latitude	3723.24751		ddmm.mmmmm
N/S Indicator	N		N=north or S=south
Longitude	12158.34161		dddmm.mmmmm
E/W Indicator	W		E=east or W=west
Speed Over Ground	0.13	Knots	
Course Over	309.62	Degrees	True
Ground			
Date	120598		ddmmyy
Magnetic variation		Degrees	E=east or W=west
Check sum	*10		
<CR> <LF>			End of message termination

#### 4.6 VTG-Course Over Ground and Ground Speed

\$GPVTG, 309.62, T, M, 0.13, N, 0.2, K\*6E

**Table 7: VTG Data Format**

Name	Example	Units	Description
Message ID	\$GPVTG		VTG protocol header
Course	309.62	Degrees	Measured heading
Reference	T		True
Course		Degrees	Measured heading
Reference	M		Magnetic
Speed	0.13	Knots	Measured horizontal speed
Units	N		Knots
Speed	0.2	Km/hr	Measured horizontal speed
Units	K		Kilometer per hour
Check sum	*6E		
<CR> <LF>			End of message termination